

# TV-20F242 STANDARD CIRCUIT DIAGRAM

## ■ NOTE ON USING CIRCUIT DIAGRAMS

### 1.SAFETY

The Components identified by the symbol  $\triangle$  are critical for safety. For continued safety, replace safety critical components only with manufacturer's recommended parts.

### 2.INDICATION OF PARTS SYMBOL [EXAMPLE]

●In the PC board :R1209→R209

### 3.NOTE FOR REPAIRING SERVICE

This model's power circuit is partly different in the GND.

Please, care must be taken for the following points.

(1)Do not touch the LIVE side GND or the LIVE side GND and the ISOLATED(NEUTRAL) side GND simultaneously. If the above caution is not respected, an electric shock may be caused. Therefore, make sure that the power cord is surely removed from the receptacle when, for example, the chassis is pulled out.

(2)Do not short between the LIVE side GND and ISOLATED(NEUTRAL) side GND or never measure with a measuring apparatus ( oscilloscope, etc.) the LIVE side GND and ISOLATED(NEUTRAL) side GND at the same time. If the above precaution is not respected , a fuse or any parts will be broken.

◇ Since the circuit diagram is a standard one, the circuit and circuit constants may be subject to change for improvement without any notice.

## CONTENTS

<b>SEMICONDUCTOR BASE CONNECTIONS</b> .....	<b>2</b>
<b>BLOCK DIAGRAMS</b> .....	<b>3</b>
<i>TV BLOCK DIAGRAM</i>	
<i>Y/C/AUDIO/HEAD AMP/IN/OUT BLOCK DIAGRAM</i>	
<i>MICON/POWER/OPERATION BLOCK DIAGRAM</i>	
<i>HIFI BLOCK DIAGRAM</i>	
<b>CONNECTION DIAGRAM</b> .....	<b>11</b>
<b>CIRCUIT DIAGRAMS</b> .....	<b>13</b>
<i>SYSCON PCB CHROMA/IF SCHEMATIC DIAGRAM</i>	
<i>SYSCON PCB Y/C/AUDIO/HEAD AMP SCHEMATIC DIAGRAM</i>	
<i>SYSCON PCB MICON SCHEMATIC DIAGRAM</i>	
<i>SYSCON PCB IN/OUT SCHEMATIC DIAGRAM</i>	
<i>SYSCON PCB SOUND AMP SCHEMATIC DIAGRAM</i>	
<i>SYSCON PCB HIFI SCHEMATIC DIAGRAM</i>	
<i>SYSCON PCB POWER SCHEMATIC DIAGRAM</i>	
<i>MAIN PCB TV POWER SCHEMATIC DIAGRAM</i>	
<i>MAIN PCB DEFLECTION SCHEMATIC DIAGRAM</i>	
<i>DIGITAL COMB FILTER PCB SCHEMATIC DIAGR</i>	
<i>CRT PCB SCHEMATIC DIAGRAM</i>	
<i>OPERATION PCB SCHEMATIC DIAGRAM</i>	
<i>AV PCB SCHEMATIC DIAGRAM</i>	
<i>DECK PCB SCHEMATIC DIAGRAM</i>	
<b>PATTERN DIAGRAMS</b> .....	<b>39</b>
<i>MAIN/CRT PCB PATTERN</i>	
<i>SYSCON PCB PATTERN</i>	
<i>AV PCB PATTERN</i>	
<i>OPERATION PCB PATTERN</i>	
<i>DECK PCB PATTERN</i>	
<b>WAVEFORMS</b> .....	<b>47</b>

## SEMICONDUCTOR BASE CONNECTIONS

### DIODE

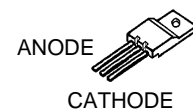

1SS133T-77  
HZ11B3L TD  
HZ27-1L TD  
MTZJ13B T-77  
MTZJ30B T-77  
MTZJ33B T-77  
MTZJ5.1B T-77  
MTZJ5.6B T-77  
MTZJ6.8B T-77  
MTZJ8.2C T-77  
SB10-03A3

11E1-EIC  
11EQS04N-TA1B2  
11ES1N-TA1B2  
RD12FB-T7

10ELS2N-TA1B2  
21DQ09N-FC4  
21DQ09N-TA2B1  
RMPG06J-G3  
RU2AM V1

SID1050CM  
SLR-342MCT32  
SLR-342VCT32

FMV-3FULF027-102 GBL06L-6177

### IC

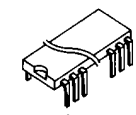

M62420SP

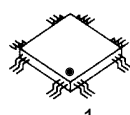

AN3662FBP  
M61203CFP  
OEC7043C

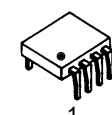

S-24C04BDP-LA

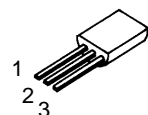

PST600H

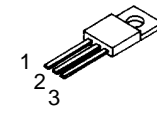

KIA7805API  
KIA7809API  
KIA7809PI

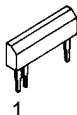

BA6955N

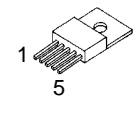

STR-G6624

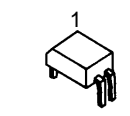

TLP621(GR)

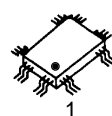

LA71067SM-MPB

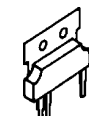

AN7522

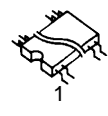

TC90A45F

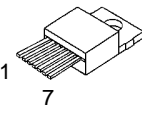

LA78040

### TRANSISTOR

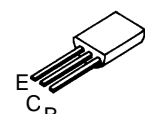

2SA1015Y(TPE2)  
2SA1318(S,T)-AA  
2SA1371(D,E)-AE  
2SA1624-AA  
2SB892(S,T)-AE  
2SC13840W  
2SC1815Y(TPE2)  
2SC2120Y(TPE2)  
2SC2909(S,T)-AA  
2SC3000-AA  
2SC3331(S,T,U)-A  
2SC945(C)-T(P,Q)  
2SD400E  
2SD734(E,F)-AA

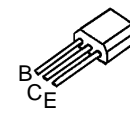

2SC1740SP(R,S) TP  
DTC114TSTP

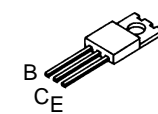

2SD1667(R,S)

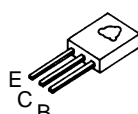

2SC2621(D,E)-RAC

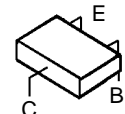

2SA1037AKT146R,S SG-276  
2SA1037KT147(R,S)  
2SC2412KT146 R,S

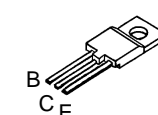

2SD2499(LB0EC1)

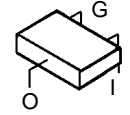

DTC114EKAT146  
DTC124EKAT146  
DTC144EKAT146

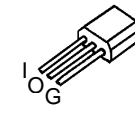

DTA124ESTP  
DTC114ESTP

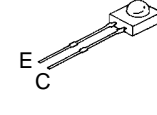

PNA2604M010R

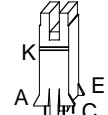

RPI-301

BLOCK DIAGRAMS

TV BLOCK DIAGRAM

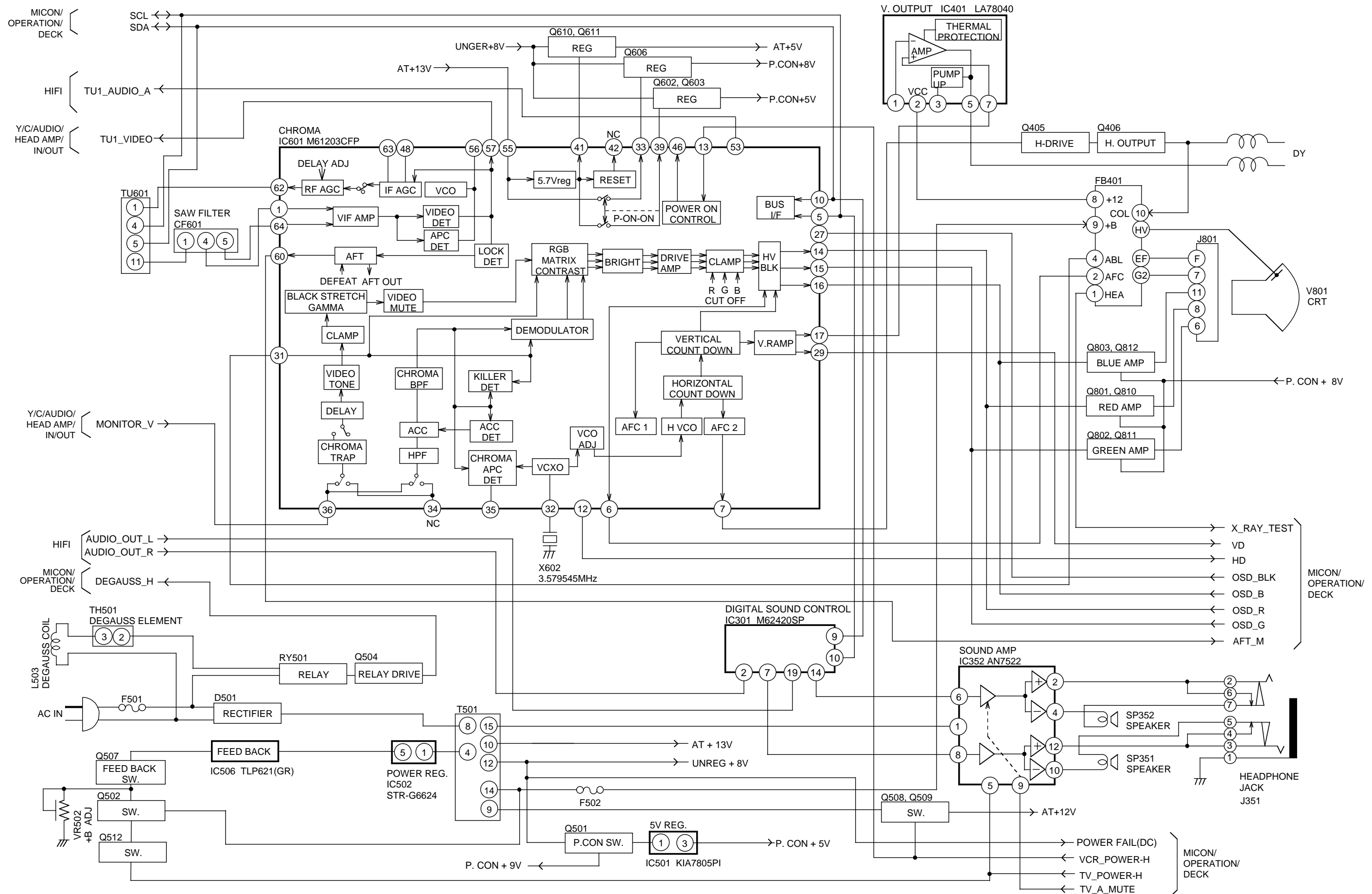

# Y/C/AUDIO/HEAD AMP/IN/OUT BLOCK DIAGRAM

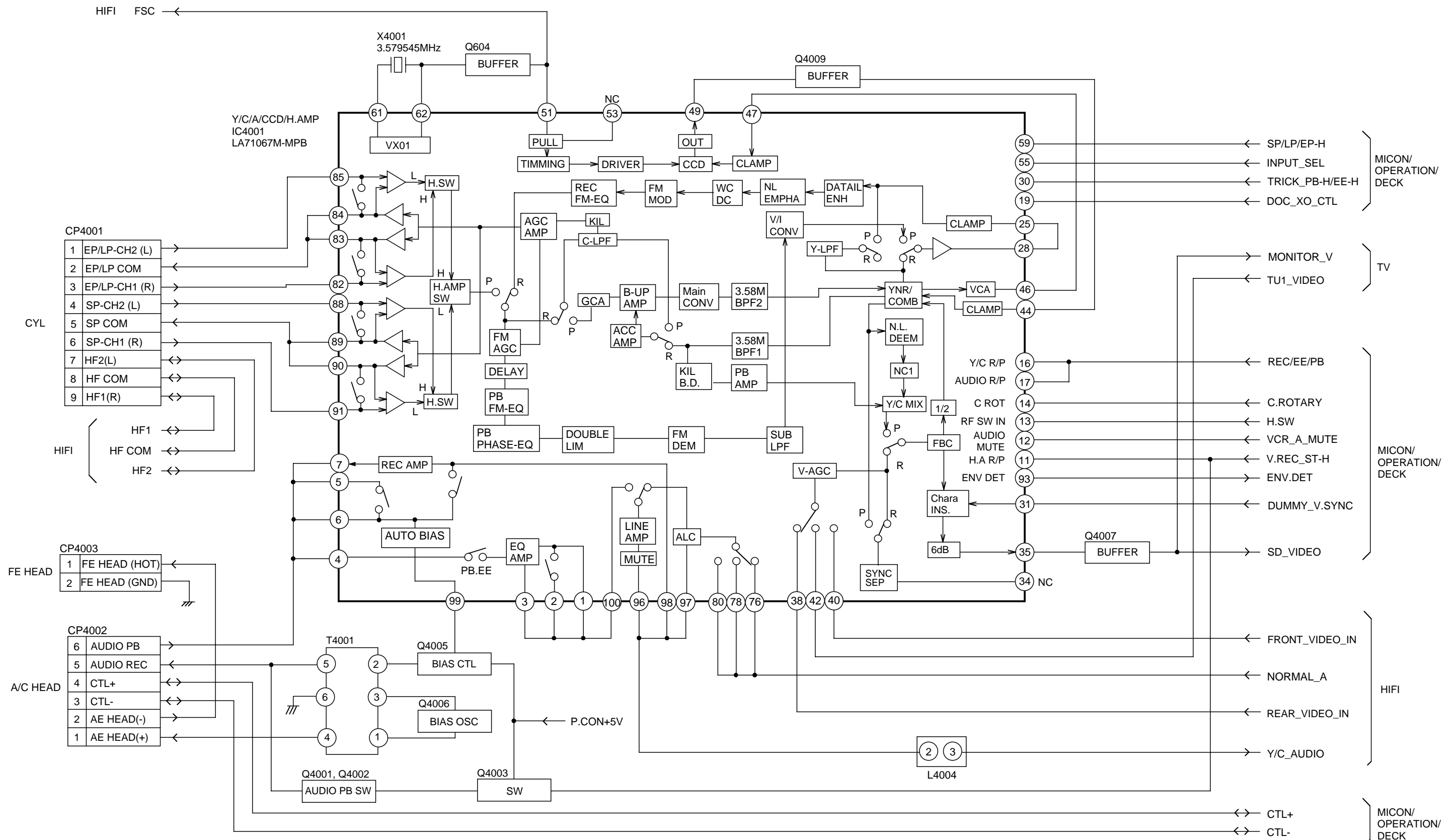

### MICON/OPERATION/DECK BLOCK DIAGRAM

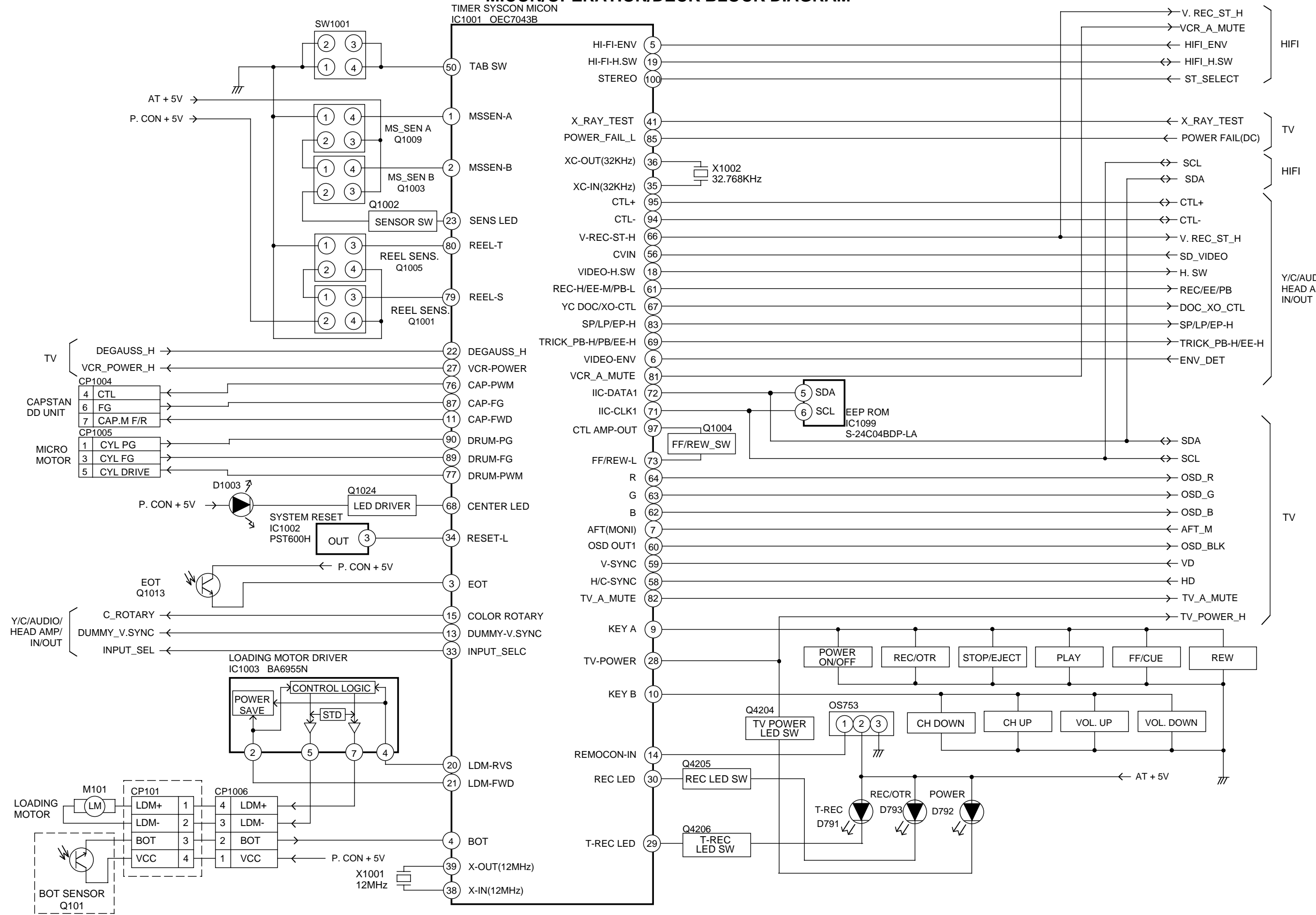

# HIFI BLOCK DIAGRAM

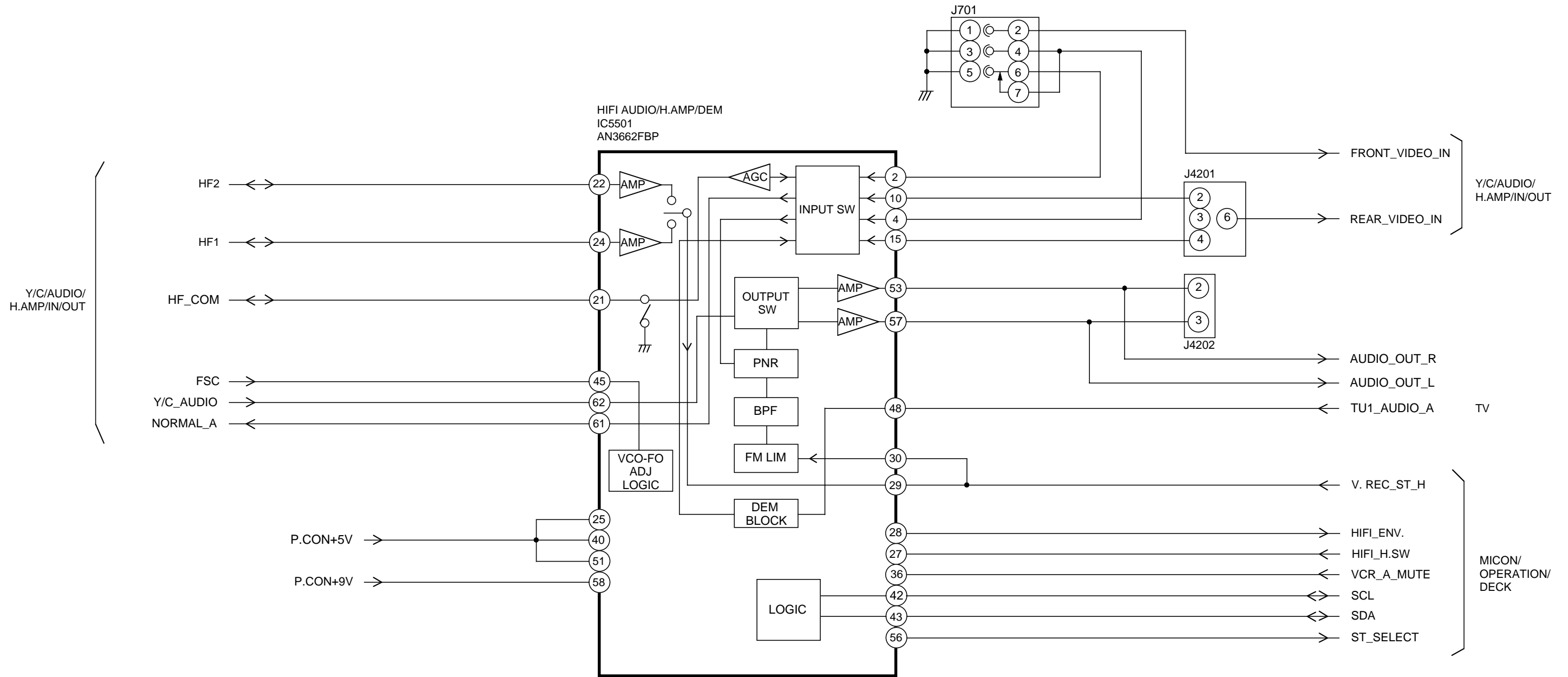

# WIRING CONNECTION DIAGRAM

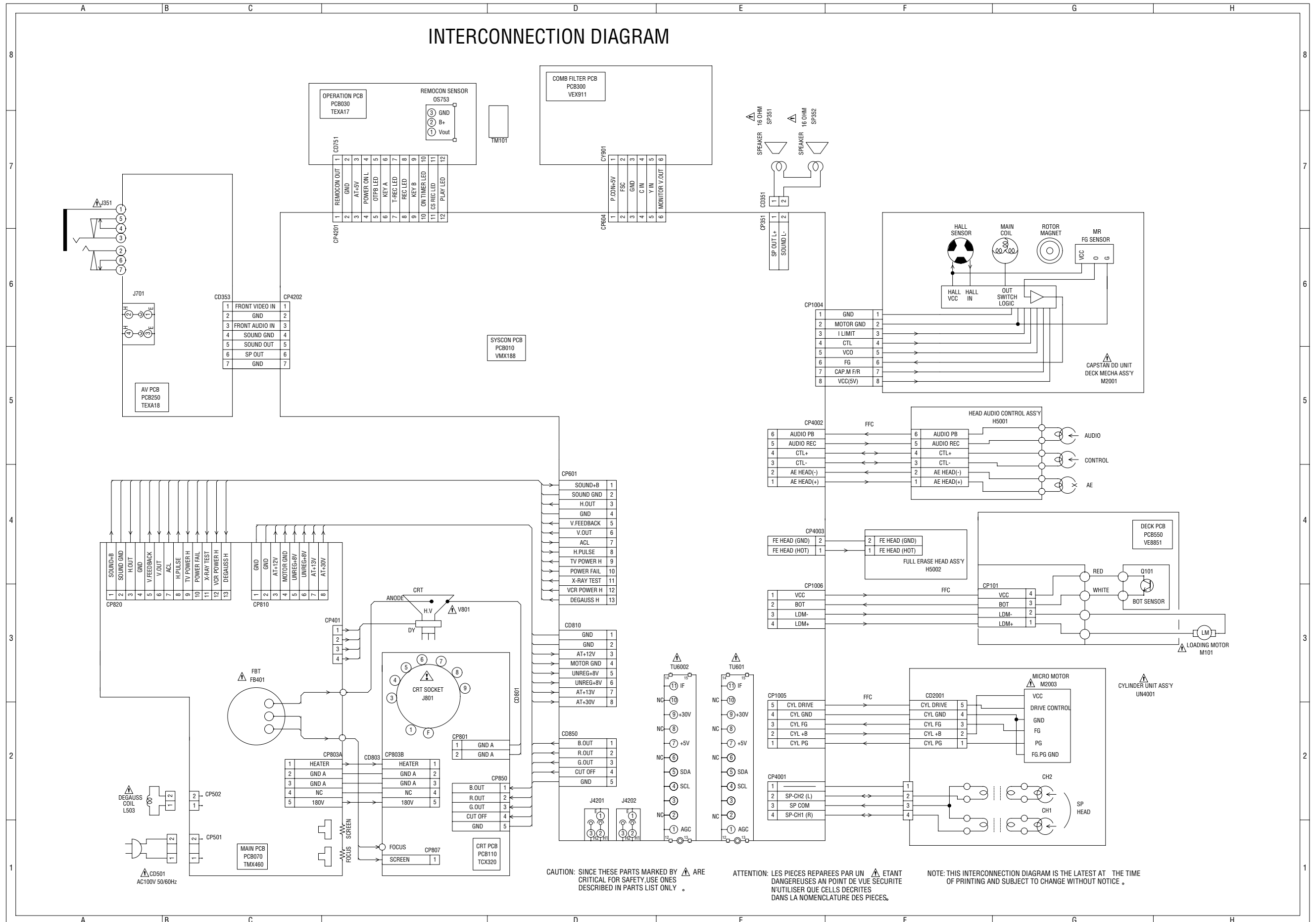

# CIRCUIT DIAGRAM

## [SYSCON PCB CHROMA/IF SCHEMATIC DIAGRAM]

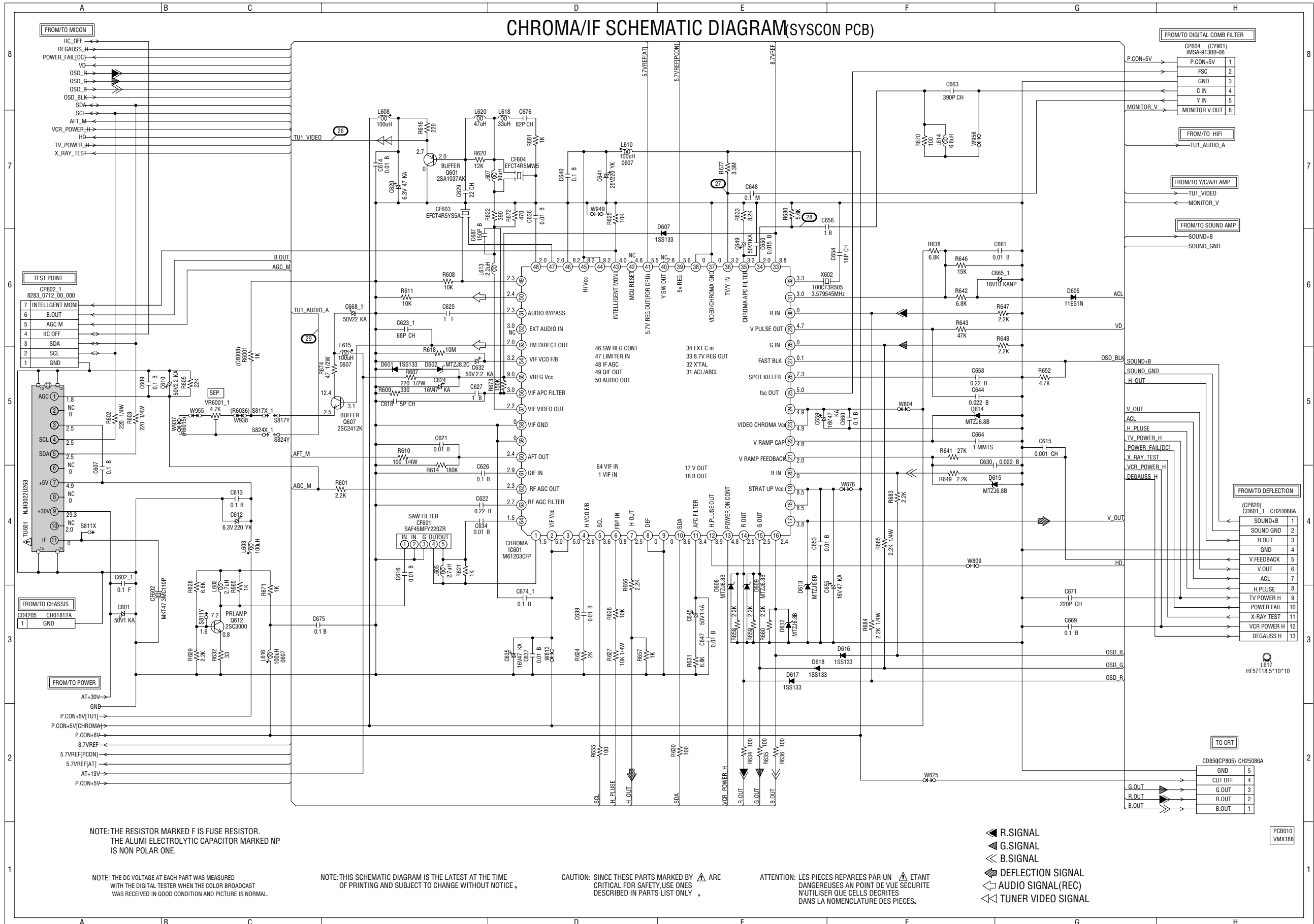



[SYSCON PCB Y/C/AUDIO/HEAD AMP SCHEMATIC DIAGRAM]

Y/C/AUDIO/HEAD AMP SCHEMATIC DIAGRAM (SYSCON PCB)

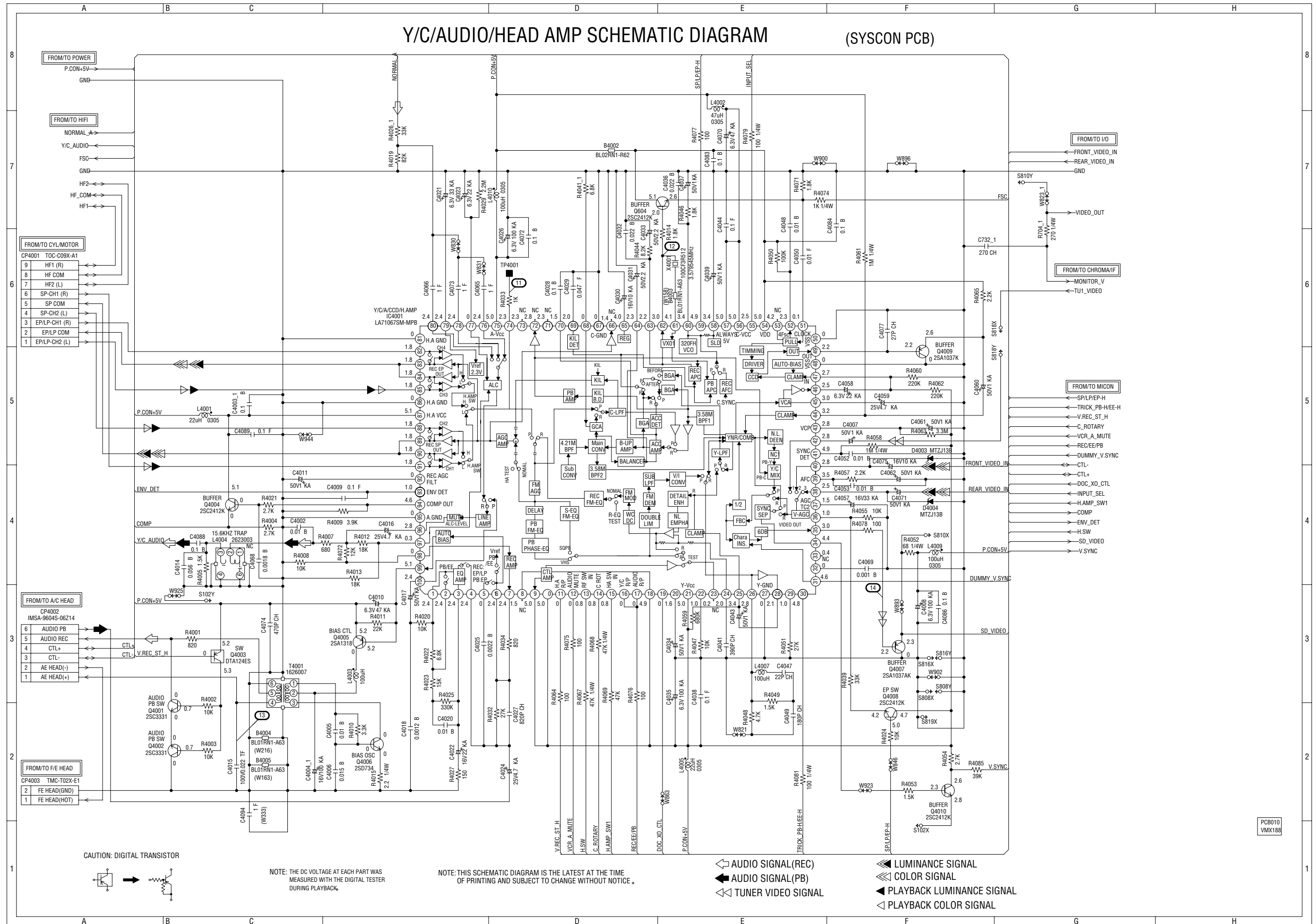



[SYSCON PCB IN/OUT DIAGRAM]

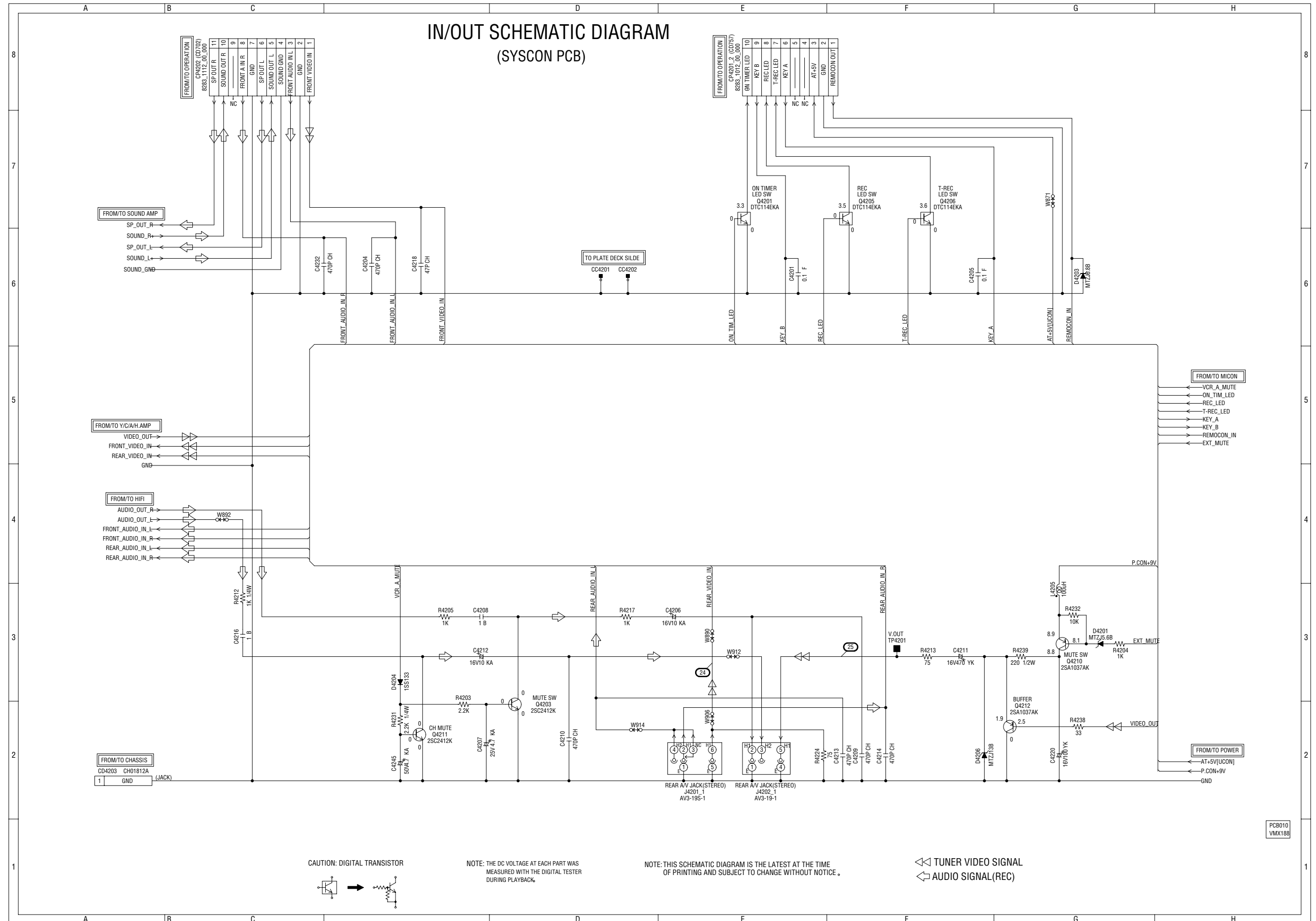

PCB010  
VMX188

[SYSICON PCB SOUND AMP CIRCUIT DIAGRAM]

SOUND AMP SCHEMATIC DIAGRAM (SYSICON PCB)

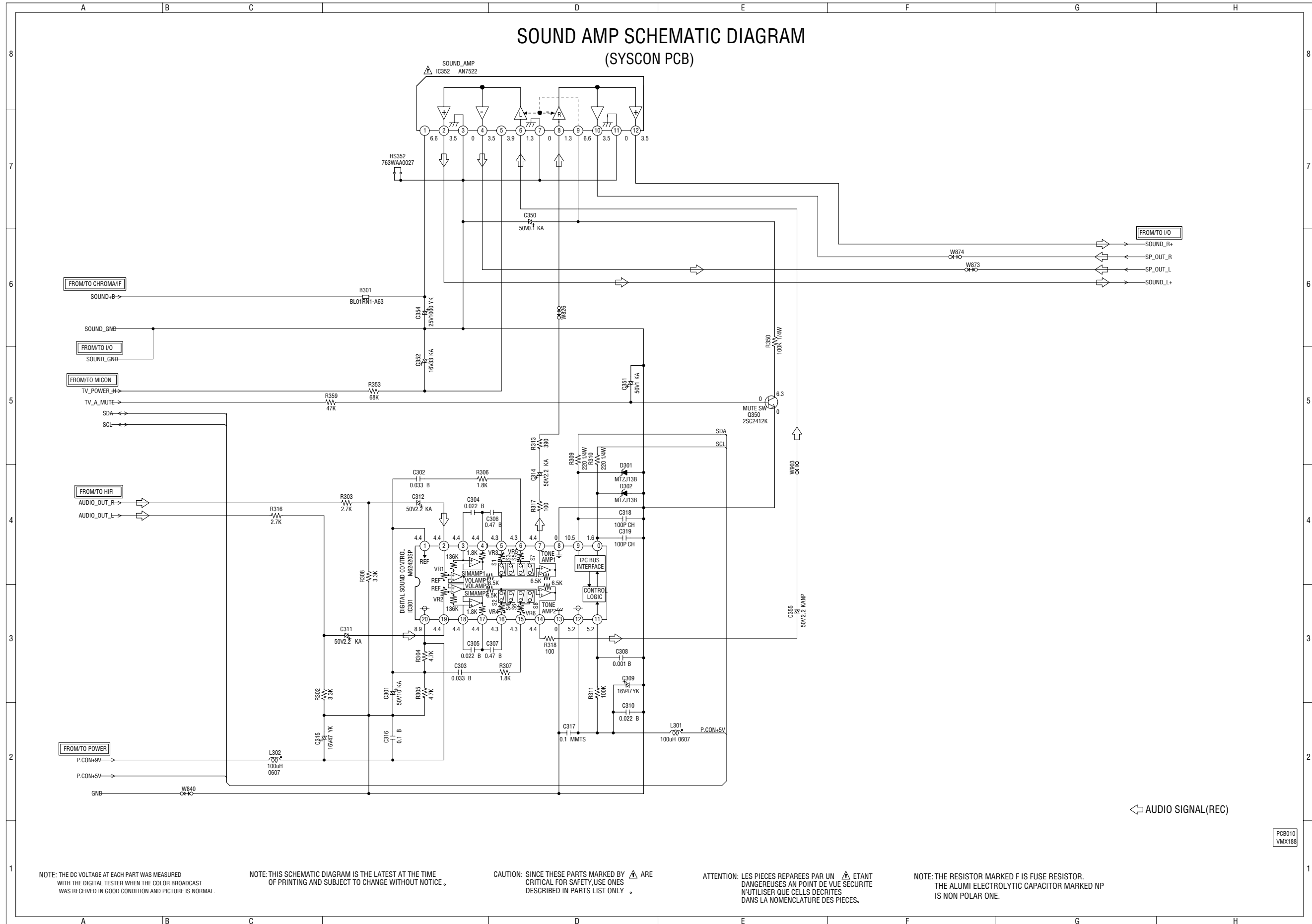

NOTE: THE DC VOLTAGE AT EACH PART WAS MEASURED WITH THE DIGITAL TESTER WHEN THE COLOR BROADCAST WAS RECEIVED IN GOOD CONDITION AND PICTURE IS NORMAL.

NOTE: THIS SCHEMATIC DIAGRAM IS THE LATEST AT THE TIME OF PRINTING AND SUBJECT TO CHANGE WITHOUT NOTICE.

CAUTION: SINCE THESE PARTS MARKED BY  $\Delta$  ARE CRITICAL FOR SAFETY, USE ONES DESCRIBED IN PARTS LIST ONLY.

ATTENTION: LES PIÈCES RÉPARÉES PAR UN  $\Delta$  ÉTANT DANGEREUSES AN POINT DE VUE SECURITE N'UTILISER QUE CELLES DÉCRITES DANS LA NOMENCLATURE DES PIÈCES.

NOTE: THE RESISTOR MARKED F IS FUSE RESISTOR. THE ALUMI ELECTROLYTIC CAPACITOR MARKED NP IS NON POLAR ONE.

← AUDIO SIGNAL(REC)

PCB010 VMX188

[SYSCON PCB HI-FI CIRCUIT DIAGRAM]

HIFI SCHEMATIC DIAGRAM  
(SYSCON PCB)

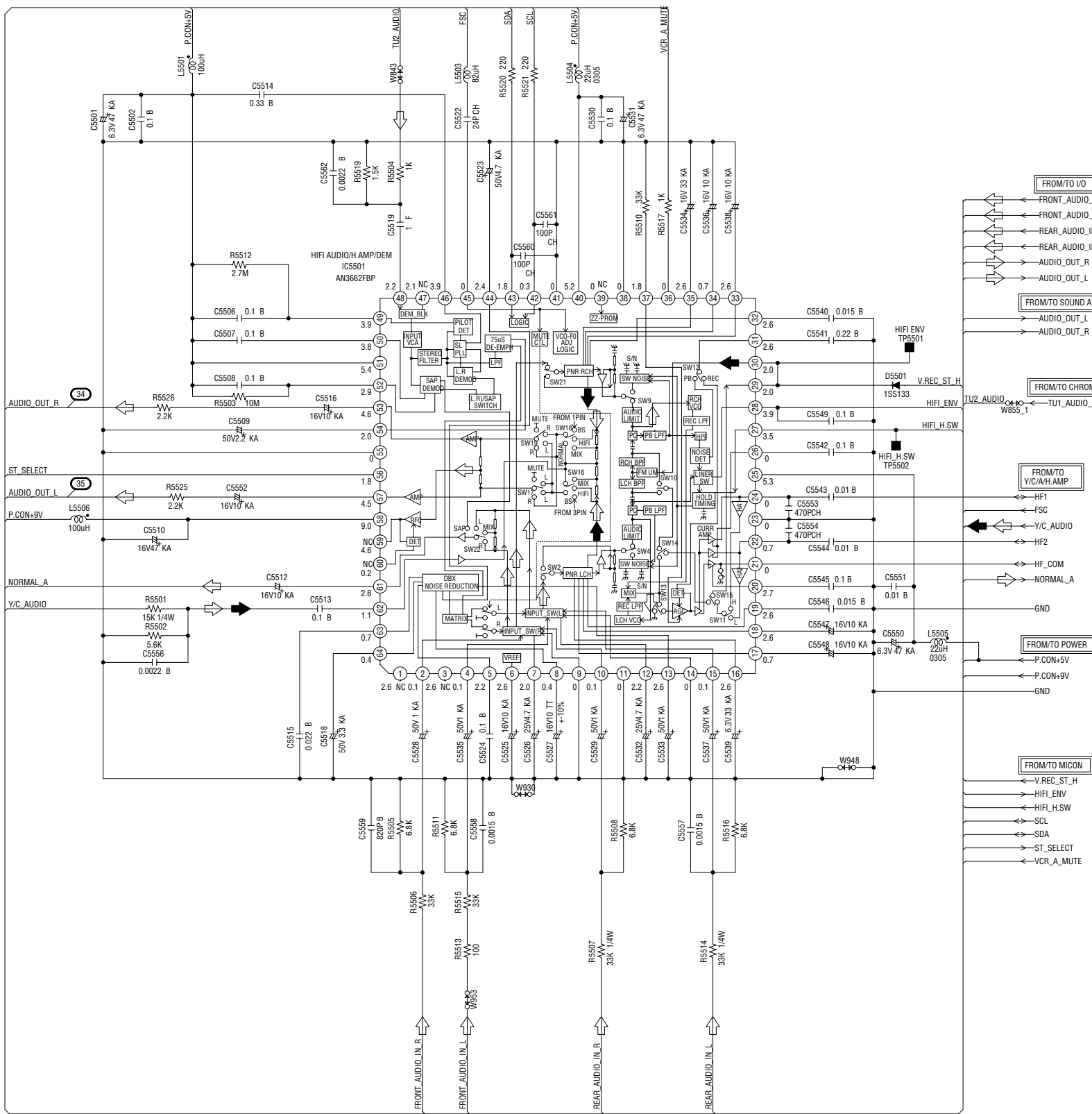

NOTE: THE DC VOLTAGE AT EACH PART WAS MEASURED WITH THE DIGITAL TESTER DURING PLAYBACK.

NOTE: THIS SCHEMATIC DIAGRAM IS THE LATEST AT THE TIME OF PRINTING AND SUBJECT TO CHANGE WITHOUT NOTICE.

◀ AUDIO SIGNAL (REC)  
▶ AUDIO SIGNAL (PB)

PC8010  
VMX188

[SYSICON PCB POWER CIRCUIT DIAGRAM]

POWER SCHEMATIC DIAGRAM

(SYSICON PCB)

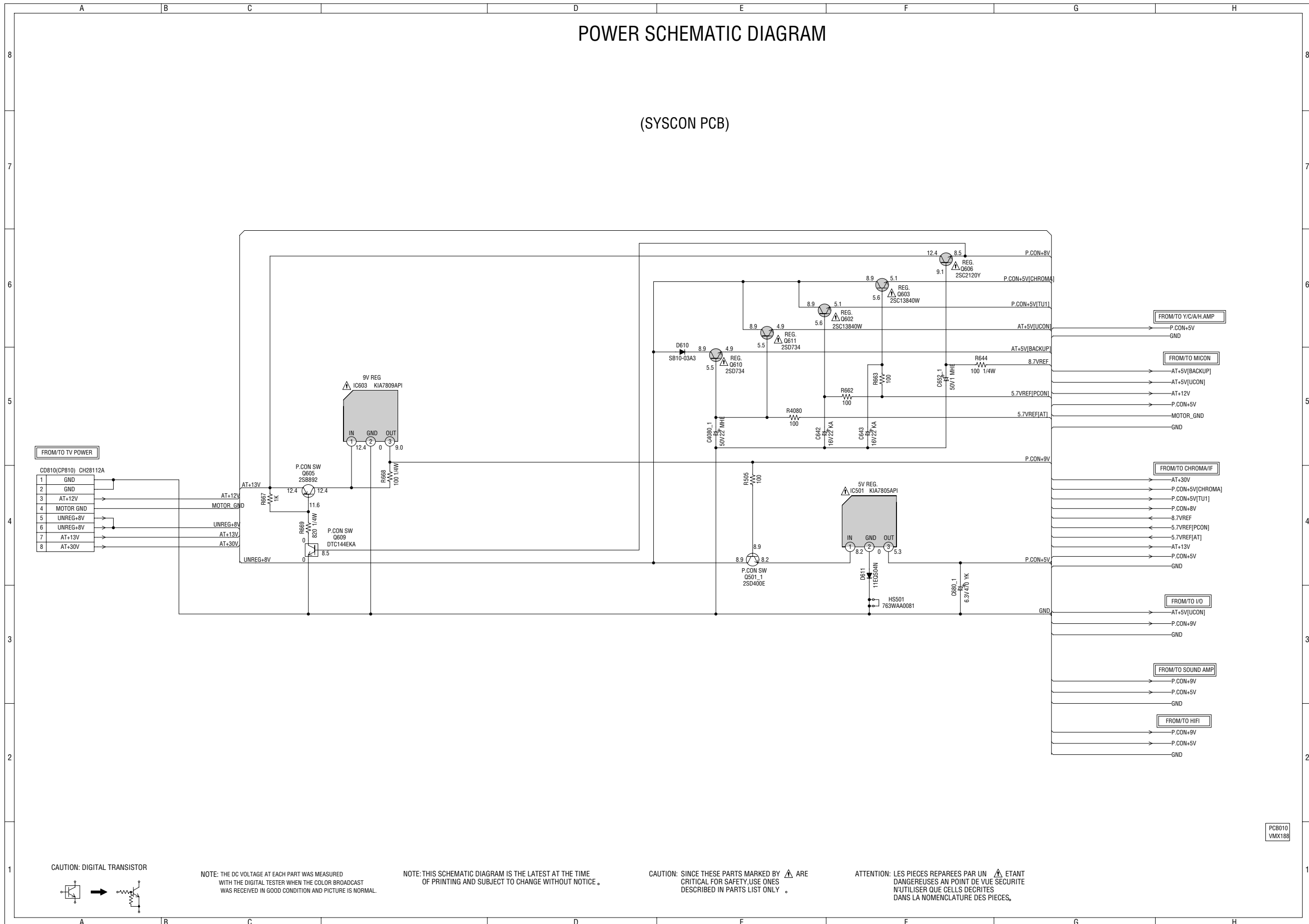

FROM/TO TV POWER

1	GND
2	GND
3	AT+12V
4	MOTOR GND
5	UNREG+8V
6	UNREG+8V
7	AT+13V
8	AT+30V

CAUTION: DIGITAL TRANSISTOR

NOTE: THE DC VOLTAGE AT EACH PART WAS MEASURED WITH THE DIGITAL TESTER WHEN THE COLOR BROADCAST WAS RECEIVED IN GOOD CONDITION AND PICTURE IS NORMAL.

NOTE: THIS SCHEMATIC DIAGRAM IS THE LATEST AT THE TIME OF PRINTING AND SUBJECT TO CHANGE WITHOUT NOTICE.

CAUTION: SINCE THESE PARTS MARKED BY ARE CRITICAL FOR SAFETY, USE ONES DESCRIBED IN PARTS LIST ONLY.

ATTENTION: LES PIECES REPARÉES PAR UN ÉTANT DANGEREUSES AN POINT DE VUE SÉCURITÉ N'UTILISER QUE CELLS DÉCRITES DANS LA NOMENCLATURE DES PIÉCES.

PCB010 VMX188



[MAIN PCB DEFLECTION CIRCUIT DIAGRAM]

DEFLECTION SCHEMATIC DIAGRAM (MAIN PCB)

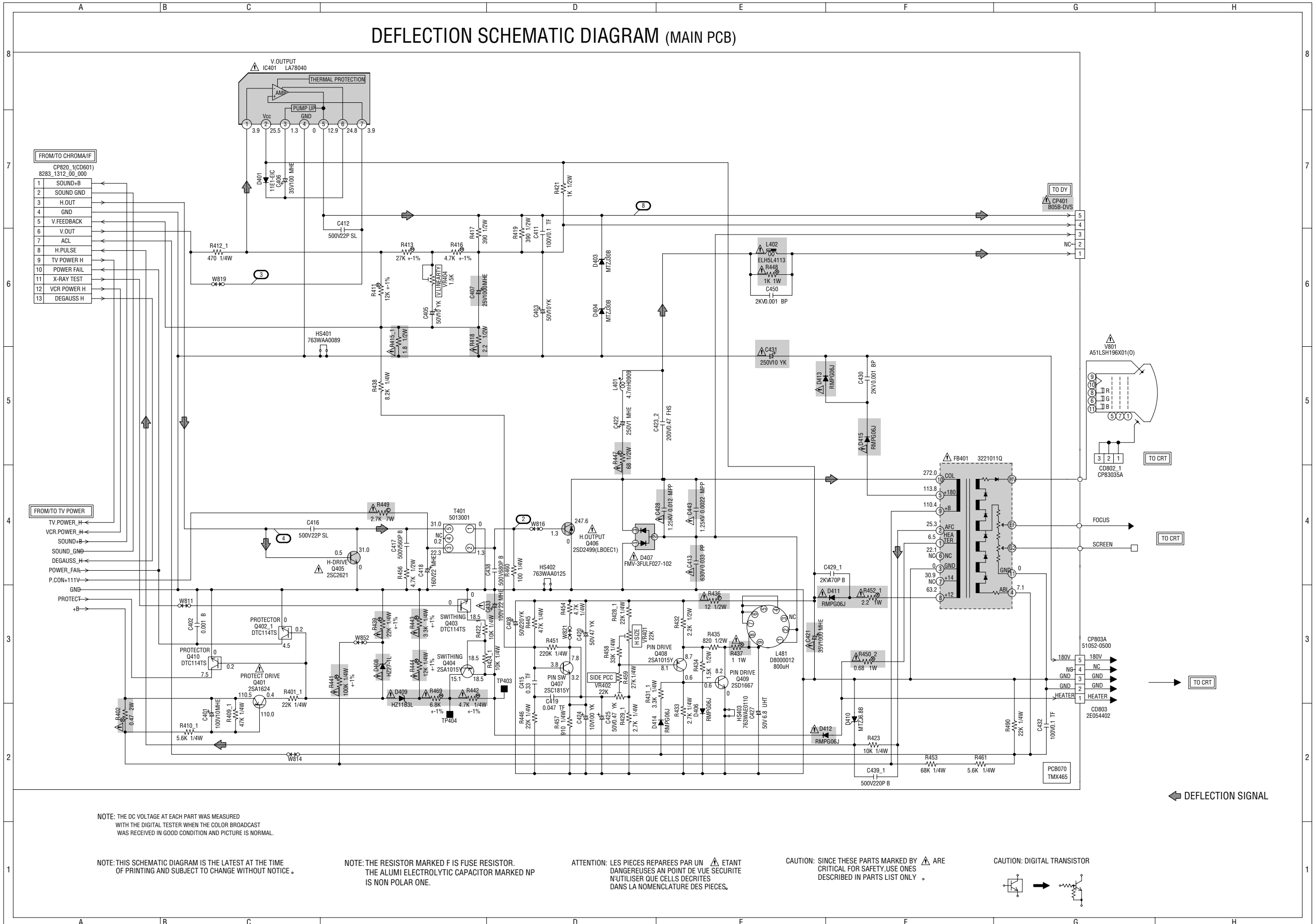

NOTE: THE DC VOLTAGE AT EACH PART WAS MEASURED WITH THE DIGITAL TESTER WHEN THE COLOR BROADCAST WAS RECEIVED IN GOOD CONDITION AND PICTURE IS NORMAL.

NOTE: THIS SCHEMATIC DIAGRAM IS THE LATEST AT THE TIME OF PRINTING AND SUBJECT TO CHANGE WITHOUT NOTICE.

NOTE: THE RESISTOR MARKED F IS FUSE RESISTOR. THE ALUMI ELECTROLYTIC CAPACITOR MARKED NP IS NON POLAR ONE.

ATTENTION: LES PIECES REPARÉES PAR UN  $\Delta$  ETANT DANGEREUSES AN POINT DE VUE SECURITE N'UTILISER QUE CELLS DECRITES DANS LA NOMENCLATURE DES PIECES.

CAUTION: SINCE THESE PARTS MARKED BY  $\Delta$  ARE CRITICAL FOR SAFETY, USE ONES DESCRIBED IN PARTS LIST ONLY.

CAUTION: DIGITAL TRANSISTOR



[DIGITAL COMB FILTER CIRCUIT DIAGRAM]

DIGITAL COMB FILTER SCHEMATIC DIAGRAM

(COMB FILTER PCB)

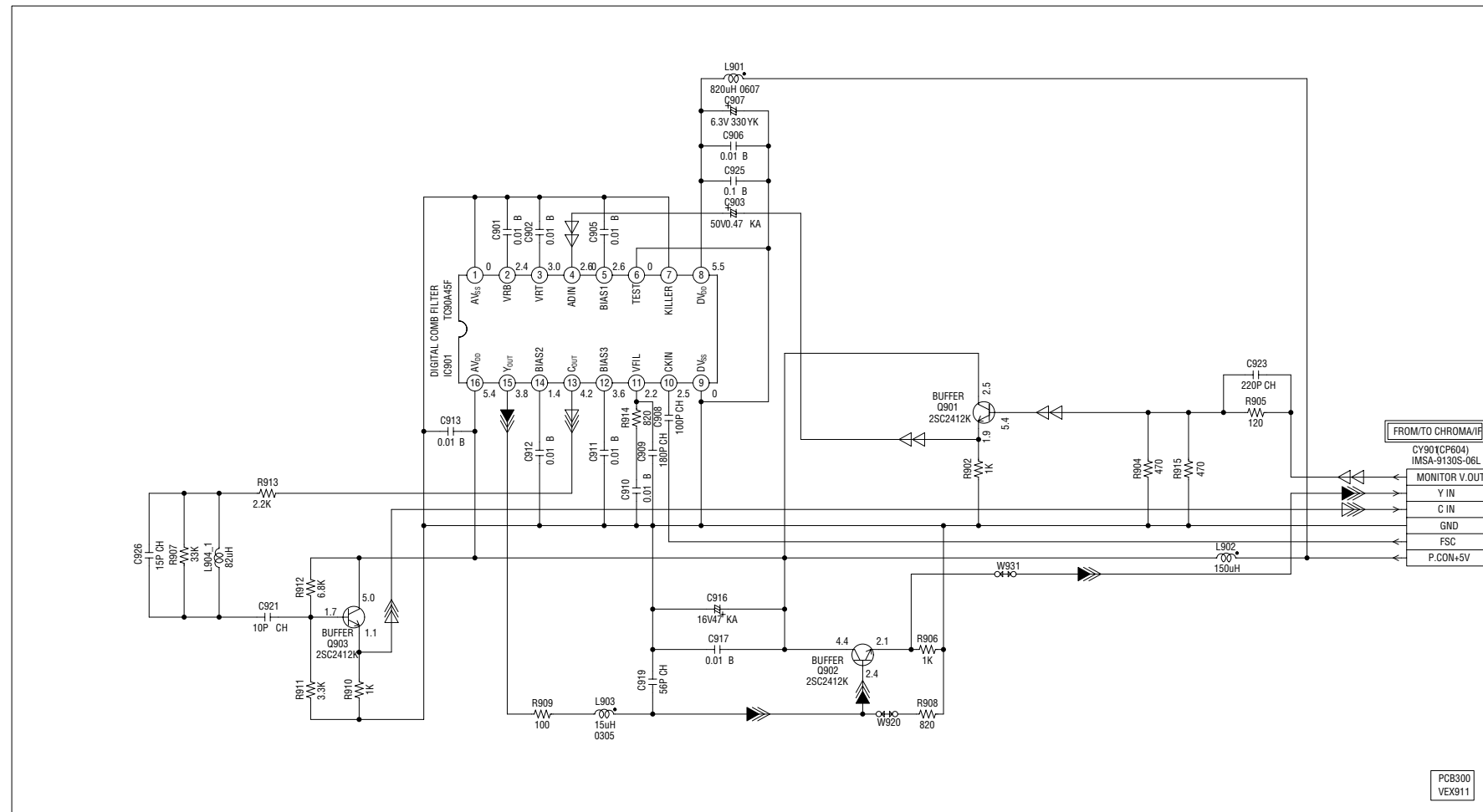

NOTE: THE RESISTOR MARKED F IS FUSE RESISTOR.  
THE ALUMI ELECTROLYTIC CAPACITOR MARKED NP  
IS NON POLAR ONE.

NOTE: THE DC VOLTAGE AT EACH PART WAS MEASURED  
WITH THE DIGITAL TESTER WHEN THE COLOR BROADCAST  
WAS RECEIVED IN GOOD CONDITION AND PICTURE IS NORMAL.

NOTE: THIS SCHEMATIC DIAGRAM IS THE LATEST AT THE TIME  
OF PRINTING AND SUBJECT TO CHANGE WITHOUT NOTICE.

◀ TUNER VIDEO SIGNAL  
◀ LUMINANCE SIGNAL  
◀ COLOR SIGNAL

[CRT PCB CIRCUIT DIAGRAM]

CRT SCHEMATIC DIAGRAM

(CRT PCB)

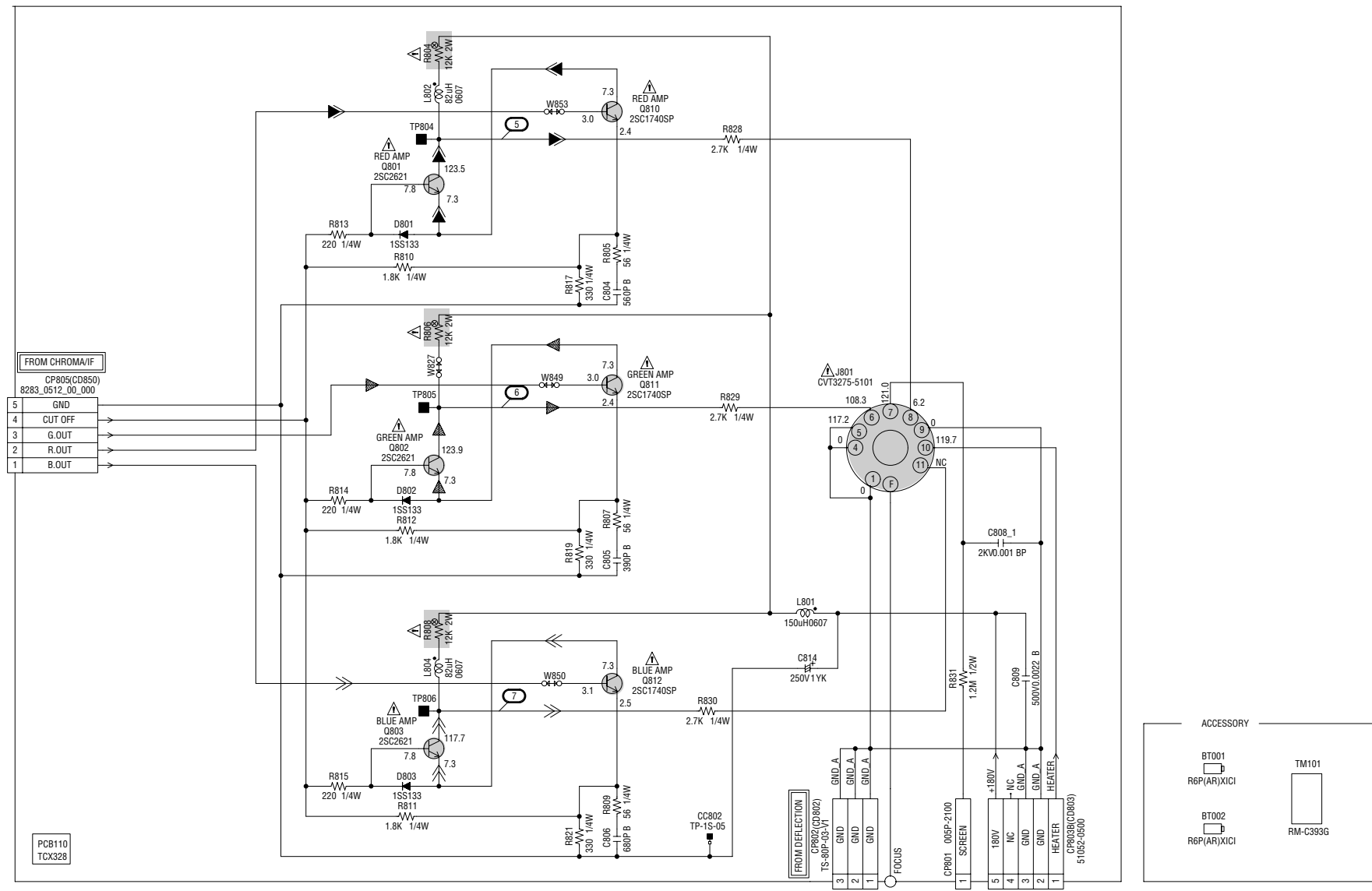

NOTE: THE DC VOLTAGE AT EACH PART WAS MEASURED WITH THE DIGITAL TESTER WHEN THE COLOR BROADCAST WAS RECEIVED IN GOOD CONDITION AND PICTURE IS NORMAL.

NOTE: THIS SCHEMATIC DIAGRAM IS THE LATEST AT THE TIME OF PRINTING AND SUBJECT TO CHANGE WITHOUT NOTICE.

CAUTION: SINCE THESE PARTS MARKED BY  $\Delta$  ARE CRITICAL FOR SAFETY, USE ONES DESCRIBED IN PARTS LIST ONLY.

ATTENTION: LES PIÈCES REPARÉES PAR UN  $\Delta$  ÉTANT DANGEREUSES AN POINT DE VUE SECURITE N'UTILISER QUE CELLS DÉCRITES DANS LA NOMENCLATURE DES PIÈCES.

[OPERATION PCB & AV PCB CIRCUIT DIAGRAM]

OPERATION SCHEMATIC DIAGRAM OPERATION PCB

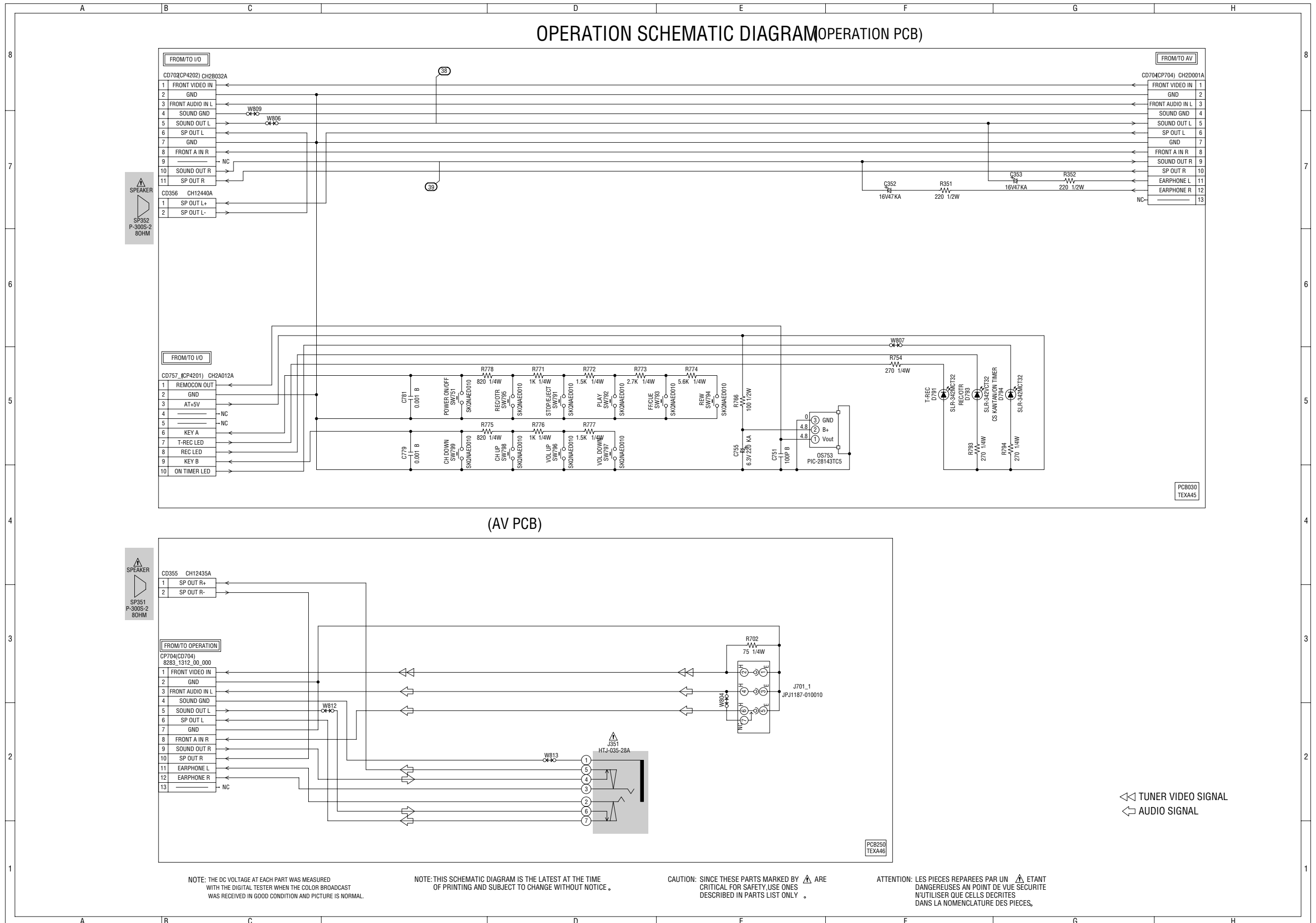

NOTE: THE DC VOLTAGE AT EACH PART WAS MEASURED WITH THE DIGITAL TESTER WHEN THE COLOR BROADCAST WAS RECEIVED IN GOOD CONDITION AND PICTURE IS NORMAL.

NOTE: THIS SCHEMATIC DIAGRAM IS THE LATEST AT THE TIME OF PRINTING AND SUBJECT TO CHANGE WITHOUT NOTICE.

CAUTION: SINCE THESE PARTS MARKED BY ARE CRITICAL FOR SAFETY, USE ONES DESCRIBED IN PARTS LIST ONLY.

ATTENTION: LES PIÈCES REPARÉES PAR UN ÉTANT DANGEREUSES AU POINT DE VUE SÉCURITÉ N'UTILISER QUE CELLES DÉCRITES DANS LA NOMENCLATURE DES PIÈCES.

[DECK PCB CIRCUIT DIAGRAM]

DECK SCHEMATIC DIAGRAM

(DECK PCB)

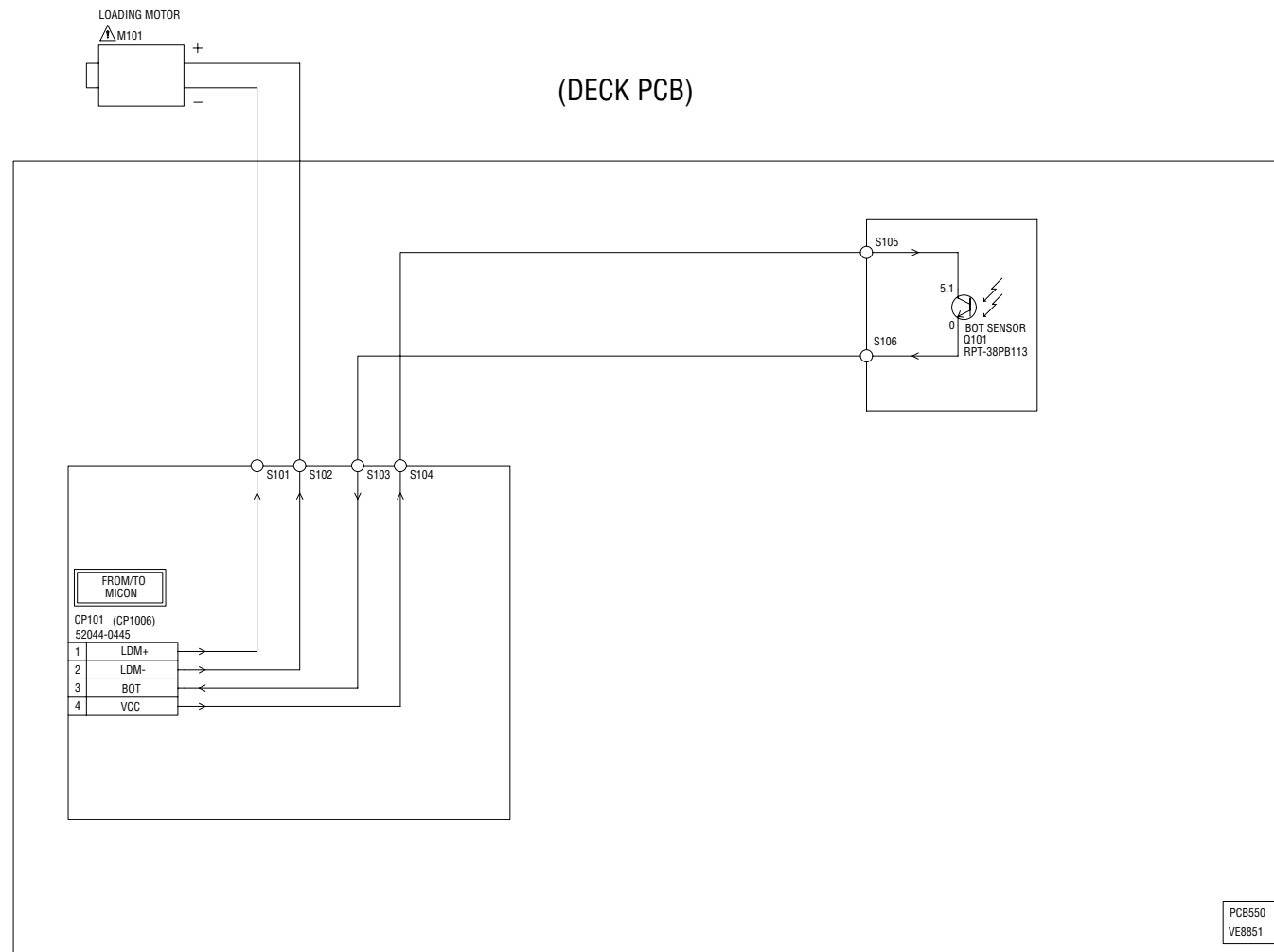

CAUTION: SINCE THESE PARTS MARKED BY ARE CRITICAL FOR SAFETY, USE ONES DESCRIBED IN PARTS LIST ONLY .

ATTENTION: LES PIÉCES REPARÉES PAR UN ÉTANT DANGEREUSES AN POINT DE VUE SECURITE N'UTILISER QUE CELLS DECRITES DANS LA NOMENCLATURE DES PIÉCES.

NOTE: THE DC VOLTAGE AT EACH PART WAS MEASURED WITH THE DIGITAL TESTER DURING PLAYBACK.

NOTE: THIS SCHEMATIC DIAGRAM IS THE LATEST AT THE TIME OF PRINTING AND SUBJECT TO CHANGE WITHOUT NOTICE .



[SYS CON/ COMB FILTER PCB PATTERN (CHIP MOUNTED PARTS)]

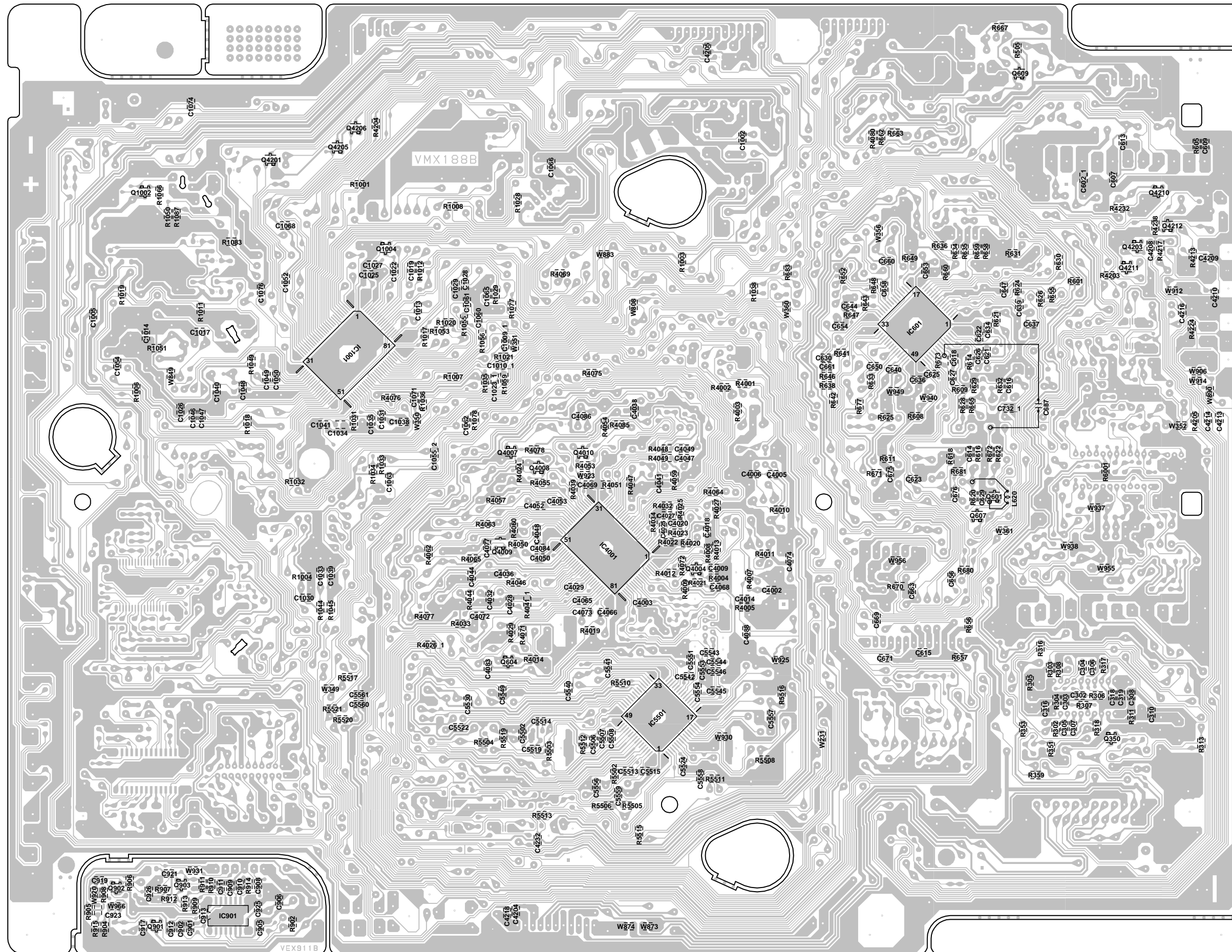



[AV PCB PATTERN]

[DECK PCB PATTERN]

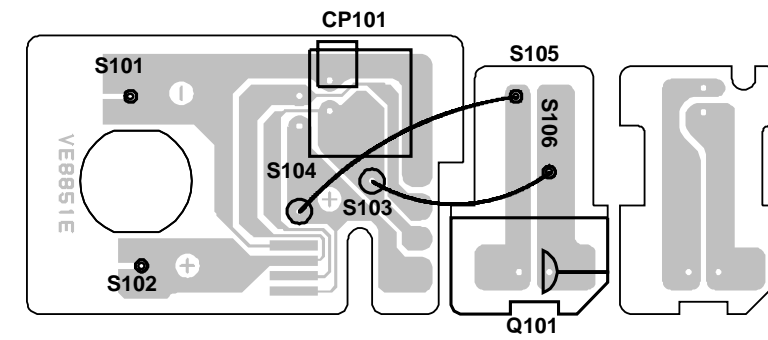
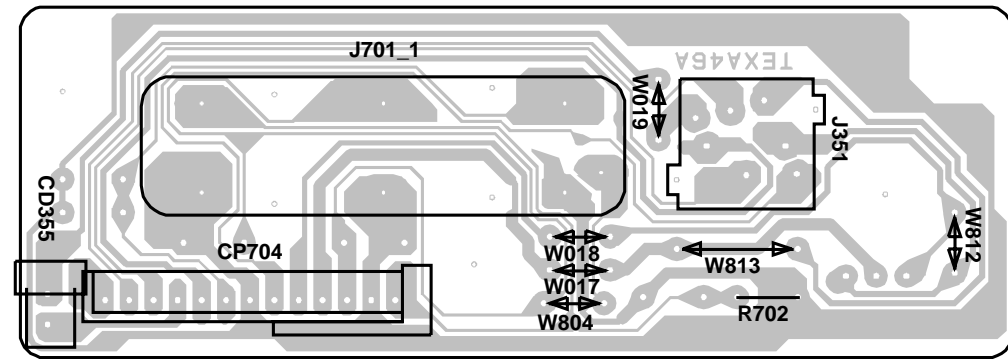

[OPERATION PCB PATTERN]

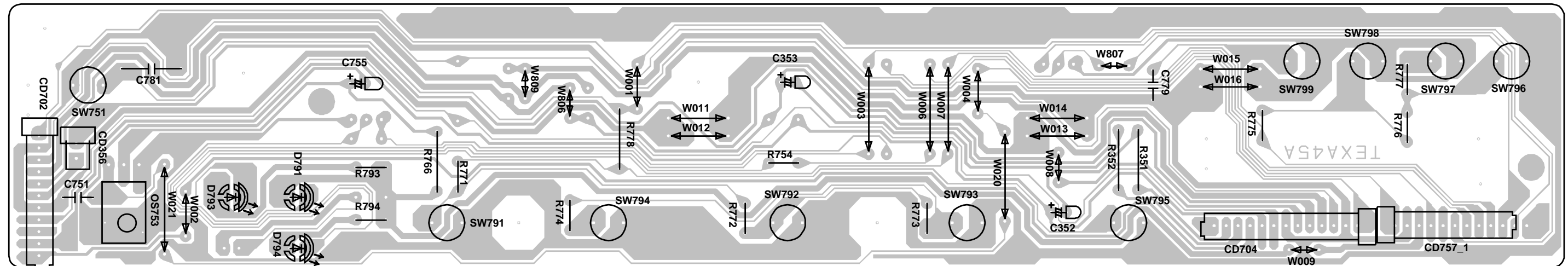



**WAVEFORMS**

**TV POWER**

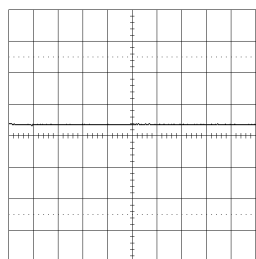

① 5V 0.1ms/div

**DEFLECTION**

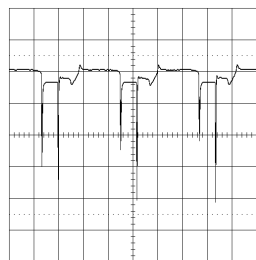

② 5V 20 s/div

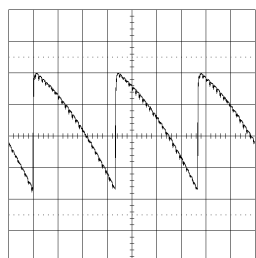

③ 0.5V 5ms/div

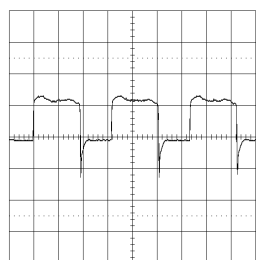

④ 0.5V 20 s/div

**CRT**

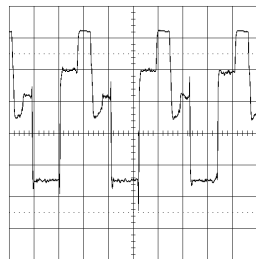

⑤ 20.0V 20 s/div

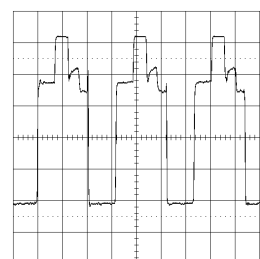

⑥ 20.0V 20 s/div

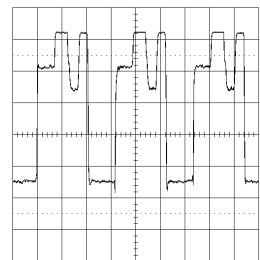

⑦ 20.0V 20 s/div

**DEFLECTION**

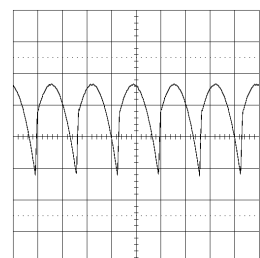

⑧ 1V 10ms/div

**TV POWER**

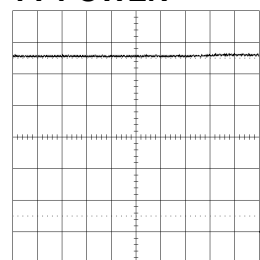

⑨ 20V 1ms/div

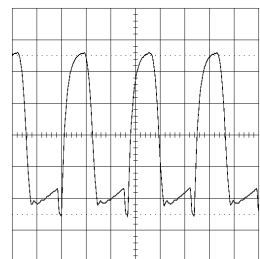

⑩ 0.5V 5 s/div

**Y/C/AUDIO/HEAD AMP**

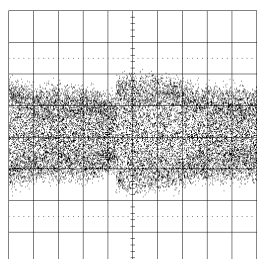

⑪ PB  
100mV 5ms/div

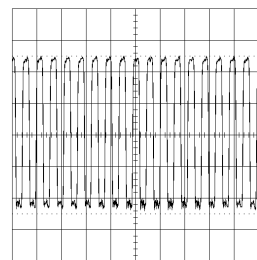

⑫ REC/PB  
100mV 0.5 s/div

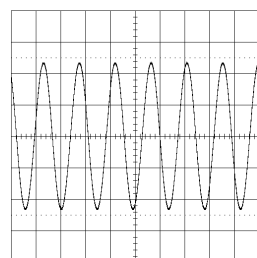

⑬ REC  
20V 10 s/div

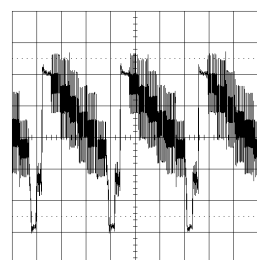

⑭ REC/PB  
0.5V 20 s/div

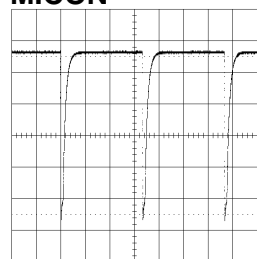

⑮ REC/PB  
1V 5ms/div

**MICON**

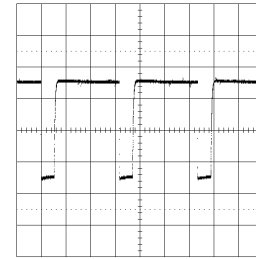

⑯ REC/PB  
2V 20 s/div

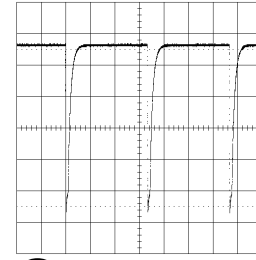

⑰ REC/PB  
1V 5ms/div

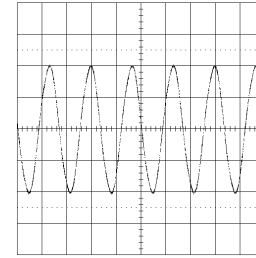

⑱ REC/PB  
1V 50ns/div

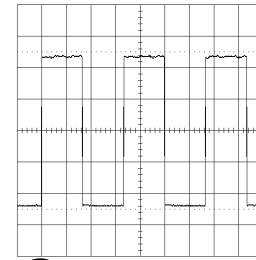

⑲ REC/PB  
1V 10ms/div

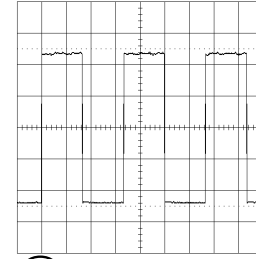

⑳ REC/PB  
1V 10ms/div

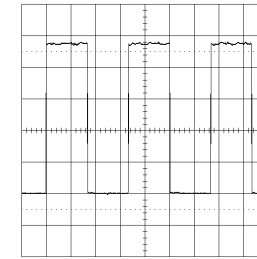

㉑ REC/PB  
1V 10ms/div

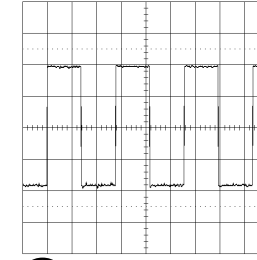

㉒ REC/PB  
1V 0.5ms/div

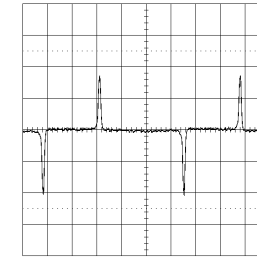

㉓ PB  
1V 2ms/div

**IN/OUT**

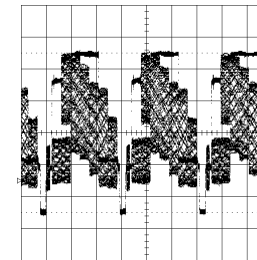

㉔ REC/PB  
200mV 20ns/div

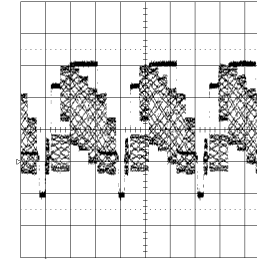

㉕ REC/PB  
0.5V 20 s/div

**CHROMA/IF**

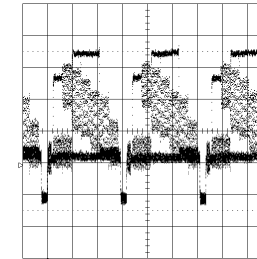

㉖ 200mV 20 s/div

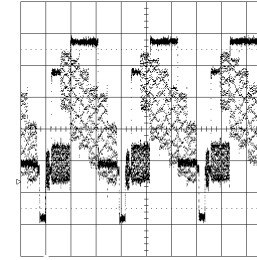

㉗ 200mV 20 s/div

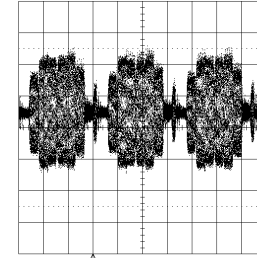

㉘ 200mV 20 s/div

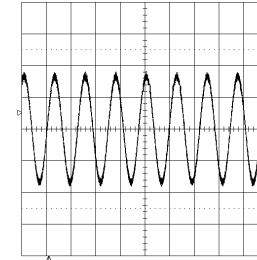

㉙ 200mV 20ms/div

**HIFI**

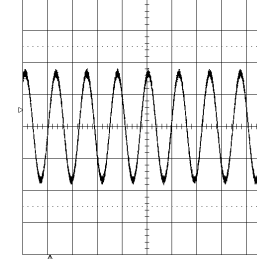

㉚ 200mV 2ms/div

NOTE: The following waveforms were measured at the point of the corresponding balloon number in the schematic diagram.

NOTE: The following waveforms were measured at the point of the corresponding balloon number in the schematic diagram.

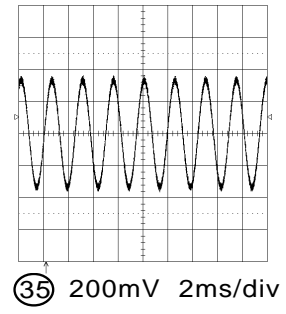

NOTE: The following waveforms were measured at the point of the corresponding balloon number in the schematic diagram.